

OPERATION MANUAL

LAUDA
ultracool



DMI-0210
rev 3
28.11.2016

UC Mini 50/60Hz

Warnings

This Operation Manual is to be followed by all persons working with the unit. It is imperative that this Manual is made freely available at all times to service personnel and is kept at the point where the unit is installed.

The basic maintenance should be carried out by properly trained personnel and, if necessary, under the supervision of a person qualified for this job.

LAUDA Ultracool S.L. personnel, or personnel authorized by LAUDA Ultracool S.L., should carry out any work in the refrigerating or electric circuit during the warranty period. After the warranty period, the work must be carried out by qualified personnel.

Disposal of Waste Equipment by Users in Private Household in the European Union.

This symbol on the product or on its packaging indicates that this product must not be disposed of with your other household waste. Instead, it is your responsibility to dispose of your waste equipment by handing it over to a designated collection point for the recycling of waste electrical and electronic equipment. The separate collection and recycling of your waste equipment at the time of disposal will help to conserve natural resources and ensure that it is recycled in a manner that protects human health and the environment. For more information about where you can drop off your waste equipment for recycling, please contact your local city office, your household waste disposal service or the shop where you purchased the product.



Table of Contents

Table of Contents

<hr/>			
1 Introduction			
	1.1	General notes	3
	1.2	Safety regulations	3
<hr/>			
2 Installation			
	2.1	Reception and inspection	4
	2.2	Transportation	4
	2.3	Site	4
	2.4	Identification labels on the Ultracool unit	5
	2.5	Water connection	5
	2.6	Electrical connection	6
<hr/>			
3 Start-up			
	3.1	Operating conditions	7
	3.2	Before the start-up of the Ultracool unit	9
	3.3	Chiller start-up	9
<hr/>			
4 Control Panel			
	4.1	Components of the control panel	11
	4.2	Controller operation	12
<hr/>			
5 Maintenance			
	5.1	Basic maintenance	14
<hr/>			
6 Troubleshooting			
	6.1	Possible causes of alarms/warnings	15
<hr/>			
7 Technical Features			
	7.1	Technical Features 50Hz	19
	7.2	Technical Features 60Hz	20
<hr/>			
8 Log Book			
	8.1	Log Book	21
<hr/>			
9 Annexes			
	9.1	Water Quality	22
	9.2	MSDS of Refrfluid B	23
<hr/>			
10 Technical Diagrams			
	10.1	Dimensional sheet	
	10.2	Flow sheet	
	10.3	Wiring sheet	
<hr/>			
11 Integrated Options			



Attention. Points of special interest to keep in mind.

1 Introduction

1.1 General notes

- This water chiller complies fully with EC-machine directives and all its main components are UL and CSA listed.
- The Company does not accept responsibility if safety regulations are not met during handling, operation, maintenance and repair, even though these may not be strictly stated in this operation manual.
- We recommend the translation of this operation manual into the native language of foreign workers.
- The usability and life cycle of the water chiller as well as avoiding premature repairs depends on proper operation, maintenance, care and competent repair under consideration of this operation manual.
- We are constantly updating our products and are confident that they respond to the latest scientific and technological demands. However, as manufacturers, we do not always know the end use or the total range of our products' applications. Therefore we cannot accept liability for our products in applications where additional safety measures may be necessary. We highly recommend that users inform us of the intended application in order to undertake additional safety measures, if necessary.

1.2 Safety regulations



The operator has to observe the national working, operating and safety regulations. Also, existing internal factory regulations must be met.

Maintenance and repair work must only be carried out by specially trained personnel and, if necessary, under supervision of a person qualified for this work.

- Protective or safety devices must not be removed, modified or readjusted.
- During operation of the water chiller none of the protective or safety devices must be removed, modified or readjusted, temporarily or permanently.
- Only use correct tools for maintenance and repair work.
- Use original spare parts only.



- All maintenance and repair work must only be carried out to the machine once it has been stopped and disconnected from the power supply. Ensure that the water chiller cannot be switched on by mistake by unplugging it.
- Do not use flammable solvents for cleaning.
- Keep the surrounding area absolutely clean during maintenance and repair work. Keep free of dirt by covering the parts and free openings with clean cloth, paper or adhesive tape.
- Ensure that no tools, loose parts or similar are left inside the system.

2 Installation

2.1 Reception and Inspection



On receipt of the Ultracool unit, it must be inspected for damage during transport. In the case of any damage, external or internal, this cannot be referred to the manufacturer because all units are checked before dispatch. **If any damage is observed, this should be documented and reported to the forwarding company. The LAUDA Ultracool S.L. warranty does not include any damages incurred during transportation.**

The refrigerant circuit controls are set before shipment of the unit. They should not be re-adjusted under any circumstances (except by an authorized service agent). This would void the warranty of the unit.

2.2 Transportation



Keep the unit upright at all times. Do not tilt when shipping or moving. **The tilting of the Ultracool unit may affect the internal suspension of the refrigerant compressor.**

The Ultracool unit must be transported by pallet jack or forklift truck.

2.3 Site

We recommend the installation of the Ultracool unit in a well-ventilated site and in a non-corrosive, dust-free atmosphere. The air renewal of the room should be at least $\frac{3}{4}$ of chiller's motor fan flow (see point 7).

The electrical protection degree of the Ultracool unit is IP44. The chiller must be protected from rain with a roof and it must be installed in such way that the control panel receives as few direct sunlight as possible.

The inlet of fresh air onto the condenser should be in the most direct way possible, avoiding any chance of air recycling.

The chiller must be installed on a solid level surface that is capable of supporting a minimum of 150 kg (330 lb).

See in the picture the minimum distances in meters (0,5m = 1,5 feet) around the Ultracool unit:

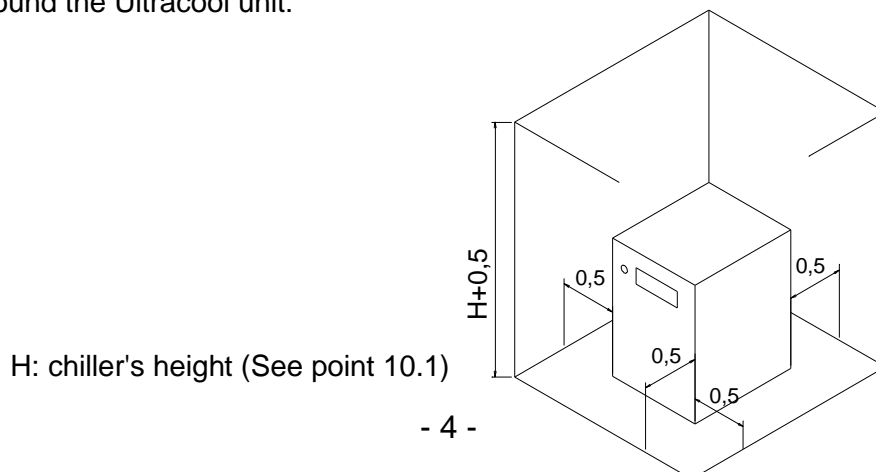

2.4 Identification Labels on the Ultracool unit

You can find the following labels stuck on the Ultracool unit:

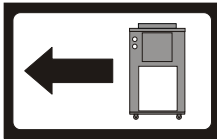

Water outlet from the Ultracool unit to the installation.

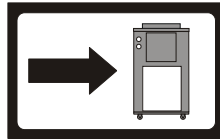

Water inlet from the installation to the Ultracool unit.

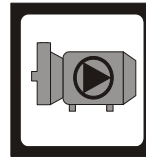

Water pump pressure.

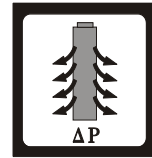

Water filter pressure drop.

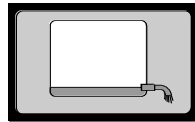

Drain.



Power supply depending on version.

2.5 Water Connection

Leave at least **1,5 metres (5 feet) of flexible pipe** right after the chiller's inlet and outlet connections. This will allow moving the chiller for a better maintenance access without dismantling the water pipes.

The chiller should be located as close as possible to the application. **Pressure drop in the pipe should not exceed 0,5 bar (7 psi). The water lines must be in pipes of at least 1/2". Maximum total pipe length depends on the pipe size:**

	Maximum total pipe length
pipe diameter 1/2"	30 m (100 feet)
pipe diameter 3/4"	60 m (200 feet)

Equivalent Length for Common Fittings and Valves:

	Type of Fitting or Valve	
	Curve 90°	Ball Valve
Equivalent pipe length m (feet)	1,5 (5)	0,3 (1)

Minimize the number of elbows in the water lines. The length of hose, number of fittings, valves, etc. will also cause an increase of the pressure drop.



We strongly advise the installation of thermal insulation for all pipes to minimize thermal losses or, at least, making sure that the pipes are opaque to the light.

The water connection of the installation of the Ultracool unit must be carried out according to the indications of the labels (stickers) present on the unit. The tank has to be filled directly by removing the chiller and tank covers.

The chiller can be installed above the application. If the chiller is installed below it, the height difference between the chiller and the application should never exceed 10 m (33 feet).



In the installations in which the water level of the circuit exceeds the maximum level of the tank inside the Ultracool unit, it will be necessary to install a non-return valve in the water outlet of the Ultracool unit and a solenoid valve in the water inlet. Terminals at 230 VAC are designed for that purpose to carry out the supply of this solenoid valve (see electrical diagram).

2.6 Electrical Connection

The electrical design of the Ultracool complies with EN-60204 norms.

Check that the supply voltage does not exceed a maximum variation of +/-10% from the nominal value indicated on the data plate of the chiller.

For the electrical supply of the Ultracool unit, use an appropriate electrical line according to the data in the characteristics plate.

The chiller has some special terminals prepared for the following functions:

- **Terminals 23 and 24, remote On/Off operation:** This chiller can be turned On and Off remotely by using an external dry contact connected to these two terminals: Contact Open = chiller Off, Contact Closed = chiller On. If this function is not used, **do not remove the wire bridge between 23 and 24**. The chiller will not turn On if these contacts are not bridged.
- **Terminals 25 and 26, external solenoid valve connection:** They can be used to supply a solenoid valve with 230VAC. If the pipes or the application are installed above the level of the chiller's outlet this valve prevents backflow when the chiller is stopped (see point 2.5). These terminals are at 230V only when the water pump is working.
- **Terminals 27 and 28, external alarm report signal:** These terminals provide a dry contact for a general alarm of the chiller. The behaviour of this contact can be adjusted in order to open or close when there is an alarm (see point 4.2).



A system of fuses or circuit breakers must be installed before the power inlet connection to the Ultracool unit. The maximum size of these protections is defined in the Ultracool characteristics plate.

3 Start-up

3.1 Operation Conditions

Water temperature at the inlet:

Nominal:	15°C (59°F)
Maximum:	30°C (86°F)

Cold water temperature at the outlet:

Nominal:	10°C (50°F)
Minimum:	7°C (45°F) (1)
Maximum:	25°C (77°F)

Temperature of the ambient air:

Nominal:	25°C (77°F)
Minimum:	0°C (32°F) (2)
Maximum:	50°C (122°F)

(1) The Ultracool units can work with cold water temperatures lower than 7°C (45°F). To do so, add ethylene glycol to the water and contact an authorized service engineer to adjust the chiller.

(2) When the Speed Regulator (SR) option is included, the Ultracool units can work with ambient temperatures until -15°C (5°F). To do so, add ethylene glycol to the water and contact an authorized service engineer to adjust the chiller.



Only an authorized service engineer can adjust the antifreeze setpoint. The following table shows the ethylene glycol concentration and the antifreeze adjustment required.

Glycol concentration (3) and antifreeze adjustment		Min Ambient Temperature		
		0°C or more	Less than 0°C until -5°C	Less than -5°C until -15°C
Cold Water Setpoint	7°C or more	0% 0°C	15% -5°C	30% -15°C
	Less than 7°C until 5°C	15% -5°C	15% -5°C	30% -15°C
	Less than 5°C until 0°C	30% -15°C	30% -15°C	30% -15°C
	Less than 0°C until -5°C	30% -15°C	30% -15°C	30% -15°C

Glycol concentration (3) and antifreeze adjustment		Min Ambient Temperature		
		32°F or more	Less than 32°F until 23°F	Less than 23°F until 5°F
Cold Water Setpoint	45°F or more	0% 32°F	15% 23°F	30% 5°F
	Less than 45°F until 41°F	15% 23°F	15% 23°F	30% 5°F
	Less than 41°F until 32°F	30% 5°F	30% 5°F	30% 5°F
	Less than 32°F until 23°F	30% 5°F	30% 5°F	30% 5°F

(3) The ethylene glycol percentage is given as % measured as weight of the total mixture. In case of any modification in the quantity of water in the installation, the concentration of ethylene glycol should be checked.

If more volume is required it is necessary to keep the ethylene glycol concentration



Do not use automotive antifreeze. Use lab grade ethylene glycol only! Do not use an ethylene glycol concentration above 30%; this would damage the water pump.

3.2 Before start-up of the Ultracool unit



Clean the application water circuit with tap water in order to be sure that there are no free particles inside. Otherwise the filter element can block up during the start-up process.



The following points must be checked:

- Water connections have been carried out (see point 2.5).
- External electrical protection is connected (see point 2.6).

3.3 Chiller start-up



Fill the tank with water of the required quality (see annex 10), the suitable glycol concentration according to point 3.1 and the Refrfluid B additive supplied with the chiller (2 liters per each 100 liters of water tank volume). Fill it directly to the tank until the maximum level of the tank is reached. After filling the tank make sure to remove any air left inside the water pump by unscrewing its purge screw until water comes out of it:

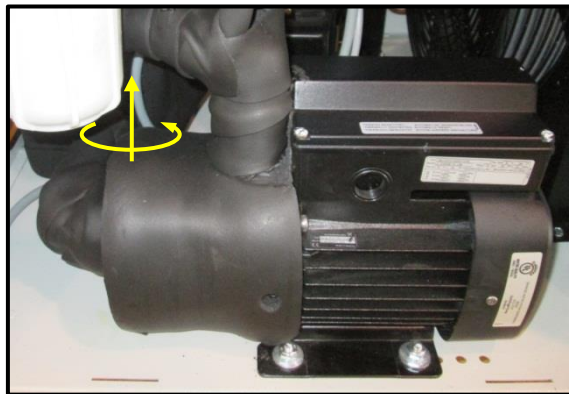

Open the water inlet and outlet valves completely as shown on the following pictures:

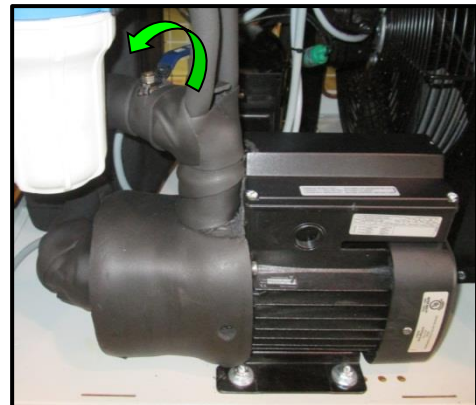

Start the Ultracool unit with the On/Off switch. After a couple of minutes or when the chiller stops by low level alarm (FL alarm), stop the Ultracool unit and refill the tank to the maximum water level.

Repeat this procedure until the water level in the tank remains constant.

When refilling the tank respect the ethylene glycol concentration as per point 3.1.

3

Start-Up



Close gradually the manual valve at the Ultracool outlet to adjust the Pump pressure on the Pump pressure gauge (see point 4.1) to the “Pnom. 1” value (Nominal pressure) indicated on the carachteristics plate of the Ultracool:

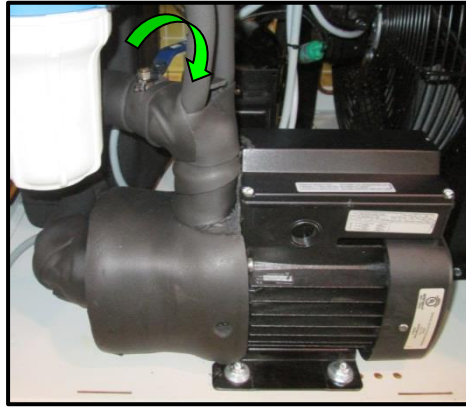

The fridge circuit has an initial delay of 2 minutes after switching the chiller On before it can start. After this time, if the water tank temperature is at least 2°C (3.6F) above the programmed value (see point 4.2), the fridge circuit starts and begins lowering the temperature.

4 Control Panel

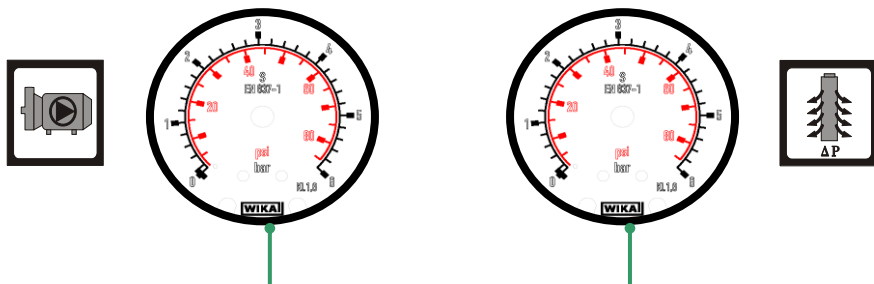

1. Pump pressure gauge

2. Filter pressure gauge

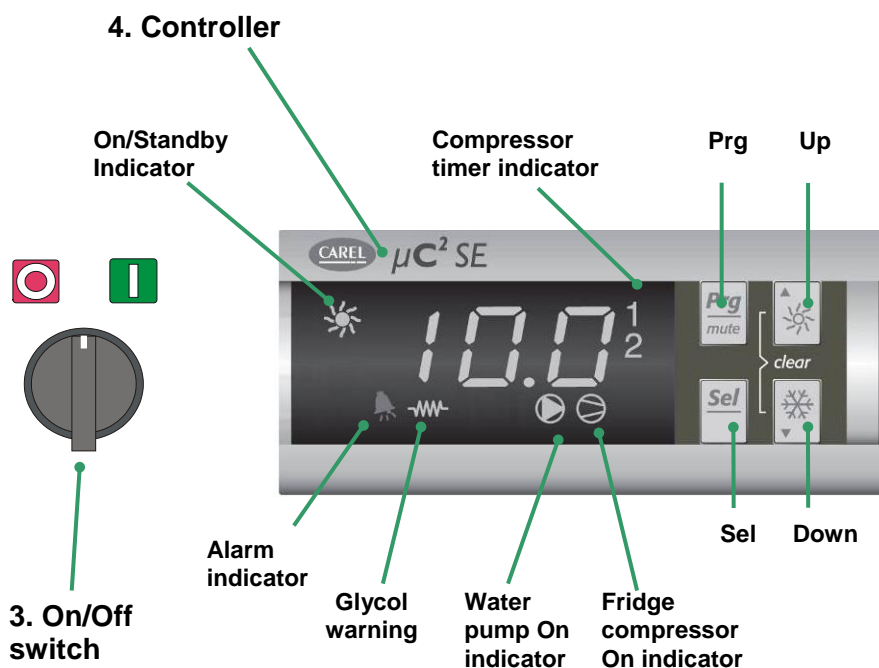

4. Controller

On/Standby Indicator

Compressor timer indicator

Prg

Up

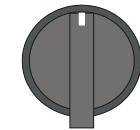

3. On/Off switch

Alarm indicator

Glycol warning

Water pump On indicator

Fridge compressor On indicator

Sel

Down

4.1 Components of the Control Panel

The control panel consists of the following elements:

1. **Pump pressure gauge:** It indicates the working pressure of the pump. While the chiller is running, its reading must be adjusted to the nominal pressure indicated on the characteristics plate (P_{nom}. 1, see point 3.3).
2. **Filter pressure gauge:** It indicates the pressure drop of the water filter and the evaporator.
3. **On/Off switch:** It turns the Ultracool unit On and Off.
4. **Controller:** It indicates the cold water temperature at the outlet of the Ultracool unit and allows changing its setpoint.

4.2 Controller operation

Standby mode: The controller has a Standby mode available. When the controller is in this mode, all motors in the Ultracool unit are stopped, but the display continues to read the water tank temperature.

When the chiller is running, the On/Standby indicator is lit. When the chiller is in Standby, this indicator remains off.

To turn the chiller On while in Standby mode or to go to Standby mode while the chiller is running, keep the **Up** button pressed during a few seconds, until the On/Standby indicator toggles On or Off.



Make sure to keep the Up button pressed continuously until the On/Standby indicator lights up; if the pressing is interrupted the controller goes into “Temperature probe reading” mode (see below) and does not turn the chiller On. If this happens, press the Prg button to exit this mode and try pressing Up again with no interruptions.

On/Standby memory: When the chiller is turned Off with the On/Off switch and later it is switched back On, the controller stays in the same mode (“On” or “Standby”) it was when the switch was turned Off.

This means that, if the chiller was originally in Standby mode when it was last switched off, the chiller will not turn On automatically after the On/Off switch is turned back On, it will remain in Standby mode.

To start the chiller again, just use the **Up** key as indicated above. Alternatively, if a remote On/Off contact is being used, the chiller can also be turned On remotely. To do so, send an On signal by opening and then closing the remote contact connected to terminals 23 and 24.

Temperature probe reading: During normal controller operation, pressing **Up** for less than 5 seconds allows displaying the current values of the different probes of the chiller. In this mode, pressing **Up** and **Down** selects the probe (b01, b02, ...) and pressing **Sel** displays the temperature currently being read by the selected probe.

While in this mode, the controller lights up the On/Standby indicator and a snowflake symbol.

To exit this mode, press **Prg** or do not press any button for at least 60 seconds.

Setting the temperature: Use the following procedure to adjust the required working temperature (between -5°C (23°F) and 25°C (77°F)):

- Press the **Sel** button for about 5 seconds. The display will show "- / -".
- Press **Down** until the display shows "- r -".
- Press **Sel** and the display will show "r01". This parameter is the temperature setpoint.
- Press **Sel** to display the current setpoint value.
- Use the **Up** and **Down** buttons to increase or to decrease the value of the setpoint.
- Press **Sel** to confirm the new value. The display will show "r01".
- Press **Prg** three times to exit the setpoint modification procedure. The display will show again the water tank temperature.

Alarm indicator: When an alarm or a warning is active, the controller lights up the Alarm indicator. If the alarm only affects the refrigerant circuit, the compressor stops. If the alarm affects the water circuit the compressor and the water pump both stop.

The display can show the following alarm and warning codes:

- Alarm code FL: Low water level.
- Alarm code A1: Antifreeze alarm.
- Alarm code LP1: Low refrigerant pressure.
- Alarm code HP1: High refrigerant pressure.
- Alarm code E1 or E2: temperature sensor faulty.
- Alarm code EPr : EEPROM error during operation.
- Alarm code EPb: EEPROM error at start-up.
- Alarm code ELS: Low supply voltage.
- Alarm code EHS: High supply voltage.
- Warning code EL1: Electromagnetic noise detected in the power supply.
- Warning code Ht: High water temperature.
- Warning code Hc1, Hc2, Hc3, Hc4: Maintenance warning.

External alarm contact adjustment (see electrical diagram):

The UC unit has two terminals that provide a dry contact for a general alarm of the chiller. In order to modify the behaviour of this contact it is necessary to modify the value of the following parameter in the controller:

If P21=0 (default value): The alarm contact closes when there is an active alarm

If P21=1: The alarm contact opens when there is an active alarm.

When the On/Off switch is Off, the alarm contact remains open.

Use the following procedure to modify the P21 parameter:

- Press the **Sel** button for about 5 seconds. The display will show "- / -".
- Press **Down** until the display shows "- P -".
- Press **Sel** and the display will show "P21".
- Press **Sel** to display the current value of P21.
- Use the **Up** and **Down** buttons to set the value to 0 or to 1.
- Press **Sel** to confirm the new value. The display will show "P21".
- Press **Prg** three times to exit the modification procedure. The display will show again the water tank temperature.

Glycol warning: This indicator is lit when the working conditions of the chiller require ethylene glycol as antifreeze agent in the water circuit to avoid freezing. Be sure that the water mixture has the suitable ethylene glycol concentration when this is lit. Please check **point 3.1** from this manual to adjust the ethylene glycol concentration of the water mixture according to the ambient temperature and antifreeze setpoint.

Pump On indicator: This remains lit while the pump is running.

Compressor On indicator: This remains lit while the compressor is running.

Compressor timer indicator: When "1" blinks it means that the controller is delaying the start of the fridge compressor. When the compressor starts "1" will stop blinking.

5 Maintenance

Units UC Mini are specially equipped with an integrated water filter inside the unit's housing at the water inlet. This filter is accessible through the left panel of the chiller. Please, observe the following maintenance guidelines.

5.1 Basic Maintenance

Weekly:

Verify that the water temperature indicated on the controller is approximately at the setpoint.

Verify that the pressure of the pump is the same as the nominal pressure (P_{nom}) indicated in the characteristics plate.

Verify the water level in the tank.

Verify the state of the water filter, if the pressure drop exceeds 1,5 bar (22 psi) change the filter element.

Monthly:

With the unit disconnected (Main power switch Off), clean the condenser with a blast of compressed air, from the inside towards the outside.

Clean the housing, internally and externally, eliminating the dust present especially on the water pump rack.

Yearly:

Change the filter element and refill the tank with water of the required quality (see annex 9), the suitable glycol concentration according to point 3.1 of this manual and the Refrfluid B additive supplied with the chiller (2 liters per each 100 liters of water tank volume).

Preventive maintenance warning (Hc1, Hc2, Hc3 or Hc4)

The controller has a preventive maintenance warning based on working hours of the Ultracool unit. When this warning appears, contact an authorised service engineer to perform the preventive maintenance.

6 Troubleshooting

6.1 Possible causes of alarms/warnings

The following chart shows the possible causes for an alarm together with the solution:

DEFAULT	CAUSE	SOLUTION	RESTART PROCEDURE
HP1 Alarm due to high pressure of the refrigerant: The pressure of the refrigerating circuit is higher than the maximum allowed (20bar, 290psig). It stops the compressor	Low airflow into the condenser The ambient temperature is too high Water temperature too high Motor fan not working	Check that there is enough free space in front of the condenser and clean the condenser if necessary Wait until the ambient temperature is lower Try to cool down the water in the circuit running the chiller with the application stopped. Reduce the water flow by closing the outlet manual valve during this process Check that the motor fan runs at the same time as the compressor. If not, contact authorized service engineer	Disconnect the chiller and connect it again by turning Off/On the power switch (element 3 on point 4.1)
LP1 Alarm due to low pressure of the refrigerant: The pressure of the refrigerating circuit is below the minimum allowed (0,5 bar, 7 psig)	Too low ambient temperature Water freezing Refrigerant gas leakage	The minimum ambient temperature is -15°C (5°F) Wait until the ambient temperature is higher Verify the ethylene glycol content (See point 3.1). If the problem persists contact authorized service engineer Contact authorized service engineer	The Low-pressure safety switch (SLP) automatically resets itself when the pressure is back to normal

DEFAULT	CAUSE	SOLUTION	RESTART PROCEDURE
FL Water level alarm	Water leak in the internal circuit of the UC Water leak in the external water circuit Water leak in the water pump UC unit installed below the application level Level switch not working	Contact authorized service engineer Check the external water pipes Contact authorized service engineer Refill the tank, if when the unit stops water overflows install the solenoid valve option Check that the level switch works properly when the tank is filled up to the maximum level after switching On the chiller. If it does not work contact authorized service engineer	Switch the chiller Off and back On to reset the alarm
A1 Antifreeze control operates continuously (See point 4)	Cold water temperature required to be below 7°C Water circuit blocked	Add ethylene glycol to the water (see point 3.1) and contact authorized service engineer to adjust the antifreeze setpoint Clean the water circuit, check for closed valves in the circuit. If necessary replace the filter element	The control will go back to normal operation when the problem is solved

DEFAULT	CAUSE	SOLUTION	RESTART PROCEDURE
	<p>Possible freezing due to low ambient temperature</p> <p>Water tank temperature sensor fault</p> <p>The pump is faulty</p>	<p>See point 3.1. Contact authorized service engineer</p> <p>Measure the water temperature inside the tank and check that it is approximately the same as shown on the controller's display</p> <p>Contact authorized service engineer</p>	
<p>Ht</p> <p>High water temperature</p>	<p>The water tank temperature is above 35°C (95°F) for some minutes</p>	<p>Check the cold water setpoint is within the limits (see point 3.1). Disconnect the application from the chiller for a while and run the chiller without load. If the problem persists contact authorized service engineer</p>	<p>The chiller is still working normally</p>
<p>The controller displays the following codes:</p> <p>E1, E2</p> <p>EPr, EPb</p> <p>ELS, EHS</p> <p>EL1</p>	<p>A temperature sensor (NTC sensor) is faulty, disconnected or short-circuited</p> <p>There is an internal memory error</p> <p>The power supply voltage is out of limits</p> <p>There are electromagnetic disturbances in the power supply</p>	<p>Contact authorized service engineer</p> <p>Contact authorized service engineer</p> <p>Check that the power supply is within the specifications: 230VAC +/-10%, 50Hz, 1 Ph or 230VAC +/-10%, 60Hz, 1 Ph</p> <p>Check the quality of the power being supplied to the chiller. Eliminate the source of the disturbances or connect the chiller to a different power supply</p>	<p>The chiller can be restarted when the faulty part is replaced</p> <p>The chiller will go back to normal operation when the problem is solved</p> <p>The chiller is still working normally. The message disappears when the disturbances stop</p>

DEFAULT	CAUSE	SOLUTION	RESTART PROCEDURE
Hc1, Hc2, Hc3, Hc4 Maintenance warning	The chiller has exceeded the working hours defined between preventive maintenances	Contact authorised service engineer for a preventive maintenance of the unit	The chiller is still working normally. The authorised service engineer will reset the warning during the preventive maintenance

7 Technical Features

7.1 Technical Features 50Hz

UC		UC 2	UC 3	UC 4	
Cooling capacity	kcal/h	1803	3496	4252	
	kW	2,1	4,1	4,9	
Water flow	l/h	337	617	827	
Water pressure	3 bar	3,3	3,0	2,8	
	5 bar	5,3	5,1	5,0	
Refrigerant circuits	Nº	1	1	1	
Compressor	kW	0,7	0,9	1,2	
	Nº	1	1	1	
Condenser	kW	2,8	4,9	6,1	
	Nº	1	1	1	
Evaporator	kW	2,1	4,1	4,9	
	Nº	1	1	1	
Motor fan	Nº	1	1	1	
	kW	0,18	0,18	0,18	
	m3/h	2400	2400	2400	
3 bar pump		kW	0,50	0,50	0,50
	max	l/h	2500	2500	2500
	min		250	250	250
	max	bar	3,4	3,4	3,4
	min		1,5	1,5	1,5
5 bar pump		kW	0,67	0,67	0,67
	max	l/h	4100	4100	4100
	min		410	410	410
	max	bar	5,5	5,5	5,5
	min		2,5	2,5	2,5
Volume water tank	l	19	19	19	
Sound Pressure Level (1)	dB(A)	40,0	42,5	42,5	
Power	ST	kW	0,9	1,0	1,3
	SP 3bar	kW	1,4	1,5	1,8
	SP 5bar	kW	1,6	1,7	2,0
Max. Fuse	A	16	16	16	
Voltage	V/Ph/Hz	230V/1Ph/50Hz			
Nominal COP		2,38	3,91	3,69	

All data related to the following conditions: Water outlet temperature 10°C (50°F) and ambient temperature 25°C (77°F).

(1) Sound Pressure Level at 5 meters from the chiller in free-field conditions.

7.2 Technical Features 60Hz

UC		UC 2	UC 3	UC 4	
Cooling capacity	kcal/h	1829	3157	3969	
	kW	2,1	3,7	4,6	
Water flow	l/h	337	617	827	
Water pressure	3 bar	3,4	3,3	3,2	
	5 bar	4,9	4,8	4,6	
Refrigerant circuits	Nº	1	1	1	
Compressor	kW	0,6	0,7	1,0	
	Nº	1	1	1	
Condenser	kW	2,7	4,3	5,6	
	Nº	1	1	1	
Evaporator	kW	2,1	3,7	4,6	
	Nº	1	1	1	
Motor fan	Nº	1	1	1	
	kW	0,25	0,25	0,25	
	m3/h	2700	2700	2700	
3 bar pump		kW	0,60	0,60	0,60
	max	l/h	3000	3000	3000
	min		300	300	300
	max	bar	3,5	3,5	3,5
	min		1,5	1,5	1,5
5 bar pump		kW	0,78	0,78	0,78
	max	l/h	4800	4800	4800
	min		480	480	480
	max	bar	5,0	5,0	5,0
	min		2,4	2,4	2,4
Volume water tank	l	19	19	19	
Sound Pressure Level (1)	dB(A)	42,5	46,8	48,2	
Power	ST	kW	0,8	0,9	1,3
	SP 3bar	kW	1,4	1,5	1,9
	SP 5bar	kW	1,6	1,7	2,0
Max. Fuse	A	16	16	16	
Voltage	V/Ph/Hz	230V/1Ph/60Hz			
Nominal COP		2,53	3,99	3,69	

All data related to the following conditions: Water outlet temperature 10°C (50°F) and ambient temperature 25°C (77°F).

(1) Sound Pressure Level at 5 meters from the chiller in free-field conditions.

8 Log Book

8.1 Log Book

Date	Remarks	Signature

9 Annexes

9.1 Water quality

In order to protect the water circuit of the Ultracool units, the water to be cooled must have specific physical/chemical properties so that it is not aggressive. If this water is outside any of the limits listed in the table below, it can seriously damage some of the materials of the Ultracool unit.

Parameter	Limit values
pH	7 – 8
Total Hardness (TH)	< 150 ppm
Conductivity	50 – 500 μ S/cm
NH ₃	< 2 ppm
Total iron ions (Fe ²⁺ and Fe ³⁺)	< 0.2 ppm
Chloride (Cl ⁻)	< 300 ppm
H ₂ S	< 0.05 ppm
Solid particles	< 150 μ m
Ethylene glycol	0% (the units with the option stainless steel pump accept as maximum 30%)

The Total Hardness is specified in ppm (mg/L) of Ca₂CO₃.

Please note that ultra-pure waters like deionised water can also be harmful for some of the materials of the Ultracool units as they have a conductivity below 50 μ S/cm.



LAUDA Ultracool S.L. will not accept any warranty for any damage caused by water that is out of one or more of the above limits.



Do not use automotive antifreeze. Use lab grade ethylene glycol only! Do not use an ethylene glycol concentration above 30%; this would damage the water pump.

9.2 MSDS Refrfluid B

TECHNICAL SHEET

CHARACTERISTICS

Concentrated fluid specially designed for the treatment and conservation of the inside of tanks and piping in cooling equipment or water recirculating chillers (closed circuit). Its composition has been designed to accomplish two different objectives using a single fluid, resistant to temperature changes:

- It contains an anticorrosive, that protects against all types of corrosion to the metal components of the system, such as iron, aluminum, copper and welds of different alloys.
- It includes protectors for refrigeration systems and industrial processes.

INSTRUCTIONS FOR USE

REFRI-FLUID-B has to be used diluted into a proportion of 2 litres of REFRI-FLUID-B in 100 litres of demineralised water.

If the machine has to work at temperatures below 0 °C it is necessary to use ethylene glycol as antifreeze agent.

With a 20% of ethylene glycol it has a large antifreeze capacity, preventing freezing at temperatures as low as -7°C. To achieve this, dilute 2 litres of REFRI-FLUID-B into a proportion of 80 litres of demineralised water and 20 litres of ethylene glycol.

It is recommended to change the cooling water at least once per year.
For other temperatures or more information see the Operation Manual.

SAFETY DATA SHEET

In accordance with Regulation (EC) No. 1907/2006 (REACH)

1. IDENTIFICATION OF THE SUBSTANCE/MIXTURE AND OF THE COMPANY /UNDERTAKING

Product identifier: REFRI-FLUID B

Relevant identified uses: Concentrated protector and anticorrosive for closed circuits.

Details of the supplier of the safety data sheet: SENIGRUP, S.L.

C-55 Km.25 Polígono Industrial Raval dels Torrents Nave-A

08297 Castellgalí (Barcelona).

Tel. +34 93 833 28 88 – Fax.+34 93 833 28 89

Emergency telephone number: +34 93 833 28 88

e-mail: senigrup@senigrup.com

2. HAZARDS IDENTIFICATION

Classification: The product has been classified and labeled according to current EC Regulations for classification of dangerous substances and preparations.

- Labelling according to Directives 67/548/EEC and 1999/45/EC



Harmful (Xn)

Risk Phrases:

R63 Possible risk of harm to the unborn child.

Safety phrases:

S2 Keep out of the reach of children.

S36/37 Wear suitable protective clothing and gloves.

S46 If swallowed, seek medical advice immediately and show this container or label.

Other hazards / phrases:

Do not swallow.

Contains: sodium 2-ethylhexanoate

- Labelling according Regulation (EC) No 1272/2008 [CLP]

Pictogram



Signal Word: **Warning**

Hazard Statements

H361d - Suspected of damaging the unborn child

Precautionary Statements

P102 Keep out of the reach of children.

P281 - Use personal protective equipment as required

Contains: sodium 2-ethylhexanoate

3. COMPOSITION / INFORMATION ON INGREDIENTS

Substance or mixture: Mixture

Chemical name	CAS number	EC number	REACH number	%	Classification	Regulation (EC) No 1272/2008
sodium 2-ethylhexanoate	19766-89-3	243-283-8	**	5-15	Xn/Repro. Cat. 3; R63	Repr. 2; H361d

** Not available or substance currently exempt from REACH registration.

For full text of R phrases, H and EUH mentioned in this Section, see Section 16. Occupational exposure limits, if available, are listed in section 8.

4. FIRST AID MEASURES

In case of accident phone to the Spanish Toxicological Information Service.Tf.+34 915620420

In case of eye contact: Rinse with plenty of water during 15 minutes keeping the eyes open and consult a doctor.

In case of skin contact: Wash off immediately with plenty of water and soap.

If swallowed: Rinse mouth, drink water, does not provoke the throwing out. Call a physician immediately.

If inhaled: Remove the fresh air. Give oxygen. Consult a physician. Move the person to fresh air and keep at rest in a comfortable position for breathing. If symptoms persist, seek medical advice and show the label or the container.

5. FIREFIGHTING MEASURES

Suitable extinguishing media: Pulverized water, alcohol-resistant foam, dry chemical or carbon dioxide.

Unsuitable extinguishing media:: High volume water jet.

Special protection equipments: In case of fire, wear appropriate protective equipment and self contained breathing apparatus with a full face protection operating in positive pressure mode.

6. ACCIDENTAL RELEASE MEASURES

Human beings protection: Restrict the area. In case of contact with the product take out the contaminated clothes and clean with plenty of water the area.

Environment protection: Do not canalize the product to public water conductions.

Clearing and collection: Collect the product with absorbent material. Clean the remaining with plenty of water.

7. HANDLING AND STORAGE

Handling: Handle in accordance with good industrial hygiene precautions and observe safety practices. Do not eat, drink or smoke in areas where this material is handled or stored.

Storage: Store according to local legislation. Store the containers in a dry, well-ventilated area away from heat and direct sunlight. Keep container tightly closed and sealed until ready for use. Store in original container. Do not store in unlabeled containers. Containers which are opened must be carefully resealed and kept upright to prevent leakage. Do not store this material near food or drinking water.

8. EXPOSURE CONTROLS/PERSONAL PROTECTION

Exposure limits:

Chemical name	Exposure limit values	
	VLA-ED (daily exposure)	VLA-EC (short-term exposure)
sodium 2-ethylhexanoate	Not established	Not established

Special person's protection equipment: Proper clothes for chemical products handling.

Breathing protection: not required.

Hands protection: rubber gloves.

Eyes protection: safety glasses.

Skin protection: body and shoes protectors.

General protection measures: Do not eat, drink nor smoke during the use of this product.

9. PHYSICAL AND CHEMICAL PROPERTIES

Appearance: liquid.

Color: red-pink

Smell: sweet.

Fusion point: Under 0°C.

Boiling point: Over 100°C.

Ignition temperature: -

Density (at 20°C): 1.01-1.02 g/cm³.

Solubility in water: may be mixed with water at all proportions.

Solubility in water (20 ° C): miscible in water.

Solubility in other solvents: alcohols and organic solvents.

PH value at 20 ° C: 9.5-10.0

Viscosity: 5-20 centipoise in Brookfield

10. STABILITY AND REACTIVITY

Conditions to avoid: Avoid the contact with rusted products.

Dangerous reactions: any special

Materials to avoid: oxidizing agents

Products of dangerous decomposition: It does not decomposed.

11. TOXICOLOGICAL INFORMATION

Information on toxicological effects: There are no experimental data available

Inhalation: No known significant effects or critical risks.

Contact with skin: In cases of severe exposure, may produce irritation.

Toxicity for reproduction: Possible risk of harm to the unborn child. Pregnant women should not be exposed to this product.

12. ECOLOGICAL INFORMATION

Behavior in the environment: Biodegradable product.

Toxic effects: Slightly hazardous.

13. DISPOSAL CONSIDERATIONS

Product: The product has to be eliminated considering European standards, national, regional and local. In waste management companies authorized.

Containers / packaging: Eliminate as the product.

The user must take into account the existence of possible regulations European, national, regional and local respect.

14. TRANSPORT INFORMATION

This product is not classified for transport

15. REGULATORY INFORMATION

15.1 Regulatory and safety, health and environment legislation for the substance or mixture.

No data available.

15.2 Chemical safety assessment

Not done a chemical safety assessment for the mixture

16. OTHER INFORMATION

Text of R phrases mentioned in Section 3:

R63 Possible risk of harm to the unborn child.

Text of H and EUH phrases mentioned in Section 3:

H361d - Suspected of damaging the unborn child

The information contained in this safety data sheet is until this date, considered true and correct. However, the data supplied and the recommendations do not imply a warranty. Because the conditions of use are beyond the control of our company, it is responsibility of the user to ensure the correct the conditions for a safe use of the product. The information contained in this safety data sheet does not represent the technical specifications. For these owes please read our data sheet technical.



EC Declaration of conformity

GB

97/23/EC (Defined by pressure equipment directive)

2006/42/EC (Known as the 'Machinery Directive')

LAUDA Ultracool S.L.

Based in Terrassa-Barcelona-Spain, Colom II Street, nº 606, Postal Code 08228

Declares that under our sole responsibility for supply/manufacture of the product:

Model

UC 2/3/4

To which this declaration relates, is in conformity with the Directive 97/23/EC issued by the EUROPEAN COMMUNITY



EC Konformitäts Erklärung

D

97/23/EC (Defeniert in der Druckgeräteverordnung)

2006/42/EC (Bekannt als 'Maschinen Weisung')

LAUDA Ultracool S.L.

Mit Sitz in Terrassa-Barcelona-Spain, Colom II Strasse, nr. 606, Postfach 08228

Erklärt, daß unserer alleinigen Verantwortung unterliegt, das Lieferung/Herstellung des Produktes:

Modell

UC 2/3/4

Auf welches diese Erklärung Bezug nimmt, den erlassenen Weisungen 97/23/EC der EUROPÄISCHEN GEMEINSCHAFT



Declaration de conformité CE

F

97/23/EC (Défini par la directive des équipements sous pression)

2006/42/EC (connue comme 'Directive Machine')

LAUDA Ultracool S.L.

Domicilié à Terrassa-Barcelona-Espagne, rue Colom II, no. 606

Déclare sous sa seule responsabilité de fournisseur/fabriqueur du produit:

Modell

UC 2/3/4

Objet de cette déclaration, est en conformité avec la Directive 97/23/EC issue de la COMMUNAUTE EUROPEENNE



Declaración de conformidad CE

E

97/23/EC (Definida por la directiva de equipos a presión)

2006/42/EC (Conocida como 'Directiva de maquinaria')

LAUDA Ultracool S.L.

Con sede en Terrassa-Barcelona-España, calle Colom II nº 606, C.P. 08228

Declara que, bajo nuestra responsabilidad como proveedores/fabricantes, el producto:

Model

UC 2/3/4

Es conforme a la Directiva 97/23/EC establecida por la COMUNIDAD EUROPEA.



EC Konformitäts Erklärung

NL

97/23/EC (Ontworpen volgens de Pressure Equipment Directive - richtlijnen)

2006/42/EC (Bekend als 'machine richtlijn')

LAUDA Ultracool S.L.

Gezeteld in Terrassa-Barcelona-Spanje, Colom II Straat, nr. 606, Postcode 08228

Verklaart dat onder volledig eigen verantwoordelijkheid voor de levering/fabricage van onderstaand product

Modell

UC 2/3/4

Waartoe deze verklaring behoort, conform is aan de richtlijn 97/23/EC, uitgegeven door de EUROPESE GEMEENSCHAP



Declaration de conformité CE

I

97/23/EC (Definita dalla direttiva dei recipienti a pressione)

2006/42/EC (conforme alla 'Direttiva Macchine')

LAUDA Ultracool S.L.

Colom II Street, nº 606, Terrassa-Barcelona Codice Postale 08228

Dichiara la responsabilità per la produzione prodotto:

Modell

UC 2/3/4

Il contenuto della presente relazione è in conformità con la Direttiva 97/23/EC della COMUNITÀ EUROPEA



Declaración de conformidad CE

CZ

97/23/EC (Definováná směrnicí pro tlaková zařízení)

2006/42/EC (Machinery Directives)

LAUDA Ultracool S.L.

Se sídlem Terrassa-Barcelona-Spain, Colom II Street, nº 606, Postal Code 08228

Z titulu své odpovědnosti výrobce a dodavatele prohlašuje ze toto prohlášení o shode se vztahuje k zařízení:

Model

UC 2/3/4

A je plně v souladu se směrnicí Evropského společenství č. 97/23/EC



EC Konformitäts Erklärung

DK

97/23/EC (Defineret af direktivet for trykluftudstyr)

2006/42/EC (Kendt som 'Maskindirektivet')

LAUDA Ultracool S.L.

Bosiddende i Terrassa-Barcelona-Spain, Colom II Street, nº 606, Postal code 08228

Erklærer under eneansvar for levering/fremstilling af produktet:

Modell

UC 2/3/4

Hvortil denne erklæring relaterer, at produktet er i overensstemmelse med Direktivet 97/23/EC udstedt af det EUROPÆISKE FÆLLESSKAB



Declaration de conformité CE

RO

97/23/EC (Conform reglementarilor de utilizare a echipamentelor sub presiune)

2006/42/EC (Cunoscuta ca 'Directiva Constructiilor de Masini')

LAUDA Ultracool S.L.

Domicilié à Terrassa-Barcelona-Espagne, rue Colom II, no. 606

Declara pe proprie raspundere ca furnizarea/ fabricarea produsului:

Modell

UC 2/3/4

La care se refera aceasta declaratie este in conformitate cu Directiva 97/23/EC emisa de COMUNITATEA EUROPEANA

LAUDA
ultracoolXavi Prats
Technical Director