

Panasonic®

Operating Instructions

Heated Incubator

MIR-H163

MIR-H263

MIR-H163

MIR-H263 Series

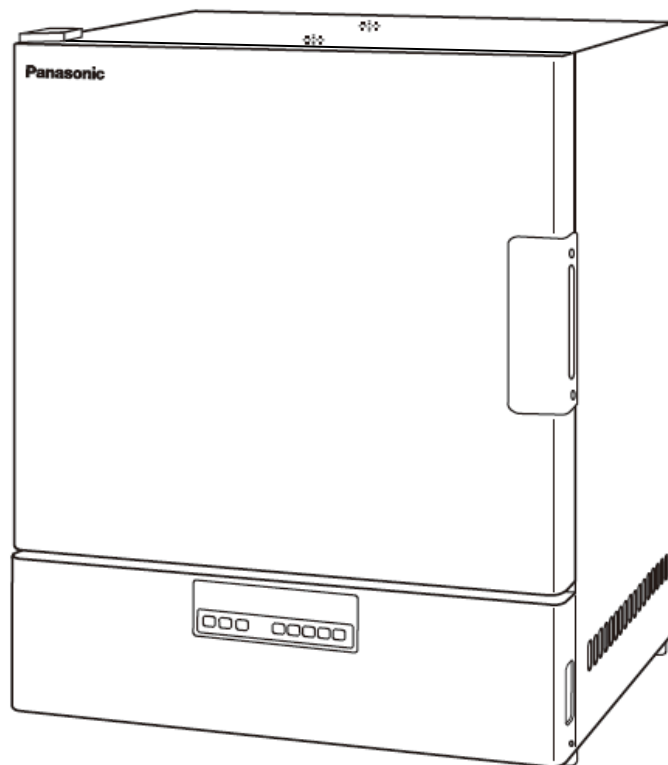

MIR-H263

Please read the operating instructions carefully before using this product, and save the operating instructions for future use.

See page 26 for all model numbers.

CONTENTS

INTRODUCTION	P. 2
PRECAUTIONS FOR SAFE OPERATION	P. 3
ENVIRONMENTAL CONDITIONS	P. 7
INCUBATOR COMPONENTS	P. 8
Control panel and keypad	P. 10
INSTALLATION SITE	P. 12
INSTALLATION	P. 13
PRELIMINARY RUN	P. 13
KEY OPERATION FLOW	P. 14
NORMAL MODE AND TIMER MODE C	P. 15
STABLE RUNNING	P. 16
STABLE RUNNING WITH DELAY TIME	P. 17
ALARMS AND SAFETY FUNCTIONS	P. 18
Operation after power failure	P. 18
ROUTINE MAINTENANCE	P. 19
Cleaning of unit	P. 19
TROUBLESHOOTING	P. 20
DISPOSAL OF UNIT	P. 21
SPECIFICATIONS	P. 26
PERFORMANCE	P. 26
SAFETY CHECK SHEET	P. 27

INTRODUCTION

- Read the operating instructions carefully before using the Product and follow the instructions for safety operation.
- Our company disavows any responsibility for safety if the Product is used for other than the intended use or used with any procedures other than those given in the operating instructions.
- Keep the operating instructions in a suitable place so that it can be referred to as necessary.
- The contents of the operating instructions are subject to change without notice for improvement of performance or functions.
- Contact our sales representative or agent if any page of the operating instructions is lost or the page order is incorrect.
- Contact our sales representative or agent if any point in the operating instructions is unclear or if there are any inaccuracies.
- No part of the operating instructions may be reproduced in any form without the expressed written permission of our company.

CAUTION

Our company guarantees the product under certain warranty conditions. Our company in no way shall be responsible for any loss of content or damage of content.

PRECAUTIONS FOR SAFE OPERATION

It is imperative that the user complies with the operating instructions as it contains important safety advice.

Items and procedures are described so that you can use this unit correctly and safely. If the precautions advised are followed, this will prevent possible injury to the user and any other person.

Precautions are illustrated in the following way:



WARNING

Failure to observe WARNING signs could result in a hazard to personnel possibly resulting in serious injury or death.

CAUTION

Failure to observe CAUTION signs could result in injury to personnel and damage to the unit and associated property.

Symbol shows;

-  This symbol means caution.
-  This symbol means an action is prohibited.
-  This symbol means an instruction must be followed.

Be sure to keep the operating instructions in a place accessible to users of this unit.















< Label on the unit >

 This mark is labeled on the cover in which the electrical components of high voltage are enclosed to prevent the electric shock.

The cover should be removed by a qualified engineer or a service personnel only.













PRECAUTIONS FOR SAFE OPERATION

WARNING

-  **Do not use the unit outdoors.** Current leakage or electric shock may result if the unit is exposed to rain water.
-  **Only qualified engineers or service personnel should install the unit.** The installation by unqualified personnel may cause electric shock or fire.
-  **Install the unit on a sturdy floor and take an adequate precaution to prevent the unit from turning over.** If the floor is not strong enough or the installation site is not adequate, this may result in injury from the unit falling or tipping over.
-  **Never install the unit in a humid place or a place where it is likely to be splashed by water.** Deterioration of the insulation may result which could cause current leakage or electric shock.
-  **Never install the unit in a flammable or volatile location.** This may cause explosion or fire.
-  **Never install the unit where acid or corrosive gases are present** as current leakage or electric shock may result due to corrosion.
-  **Always ground (earth) the unit to prevent electric shock.** If the power supply outlet is not grounded, it will be necessary to install a ground by qualified engineers.
-  **Never ground the unit through a gas pipe, water main, telephone line or lightning rod.** Such grounding may cause electric shock in the case of an incomplete circuit.
-  **Connect the unit to a power source as indicated on the rating label attached to the unit.** Use of any other voltage or frequency other than that on the rating label may cause fire or electric shock.
-  **Never store volatile or flammable substances** in this unit if the container cannot be sealed. These may cause explosion or fire.
-  **Do not insert metal objects such as a pin or a wire into any vent, gap or any outlet on the unit.** This may cause electric shock or injury by accidental contact with moving parts.
-  **Use this unit in safe area when treating the poison, harmful or radiate articles.** Improper use may cause bad effect on your health or environment.
-  **Turn off the power switch (if provided) and disconnect the power supply to the unit prior to any repair or maintenance** of the unit in order to prevent electric shock or injury.
-  **Do not touch any electrical parts (such as power supply plug) or operate switches with a wet hand.** This may cause electric shock.







PRECAUTIONS FOR SAFE OPERATION

WARNING

-  **Ensure you do not inhale or consume medication or aerosols** from around the unit at the time of maintenance. These may be harmful to your health.
-  **Never splash water directly onto the unit** as this may cause electric shock or short circuit.
-  **Never put containers with liquid on the unit** as this may cause electric shock or short circuit when the liquid is spilled.
-  **Never bind, process, or step on the power supply cord, or never damage or break the power supply plug.** A broken supply cord or plug may cause fire or electric shock.
-  **Do not use the supply cord if its plug is loose.** Such supply cord may cause fire or electric shock.
-  **Never disassemble, repair, or modify the unit yourself.** Any such work carried out by an unauthorized person may result in fire, or electric shock or injury due to a malfunction.
-  **Disconnect the power supply plug if there is something wrong with the unit.** Continued abnormal operation may cause electric shock or fire.
-  **When removing the plug from the power supply outlet, grip the power supply plug, not the cord.** Pulling the cord may result in electric shock or fire by short circuit.
-  **Disconnect the power supply plug** before moving the unit. Take care not to damage the power cord. A damaged cord may cause electric shock or fire.
-  **Disconnect the power plug when the unit is not used for long periods.** Keeping the connection may cause electric shock, current leakage, or fire due to the deterioration of insulation.
-  If the unit is to be stored unused in an unsupervised area for an extended period, **ensure that children do not have access and that doors cannot be closed completely.**
-  **The disposal of the unit should be accomplished by appropriate personnel.** Remove doors to prevent accidents such as suffocation.
-  **Do not put the packing plastic bag within reach of children** as suffocation may result.

PRECAUTIONS FOR SAFE OPERATION

CAUTION

-  This unit must be plugged into a dedicated circuit protected by branch circuit breaker.
-  Use a dedicated power source as indicated on the rating label attached to the unit. A multiple-tap may cause fire resulting from abnormal heating.
-  **Never store corrosive substances such as acid or alkali** in this unit if the container cannot be sealed. These may cause corrosion of inner components or electric parts.
-  **Check the setting when starting up of operation after power failure or turning off of power switch.** The stored items may be damaged due to the change of setting.
-  **Be careful not to tip over the unit** during movement to prevent damage or injury.
-  **Prepare a safety check sheet** when you request any repair or maintenance for the safety of service personnel.

ENVIRONMENTAL CONDITIONS

This equipment is designed to be safe at least under the following conditions (based on the IEC-61010-1):

- Indoor use;
- Altitude up to 2000 m;
- Temperature 5°C to 40°C
- Maximum relative humidity 80% for temperature up to 31°C decreasing linearly to 50% relative humidity at 40°C;
- Mains supply voltage fluctuations up to $\pm 10\%$ of the nominal voltage;
- Transient overvoltages up to the levels of OVERVOLTAGE CATEGORY II ;
- Temporary OVERVOLTAGES occurring on the mains supply;
- Applicable pollution degree of the intended environment (POLLUTION DEGREE 2 in most cases);

INCUBATOR COMPONENTS

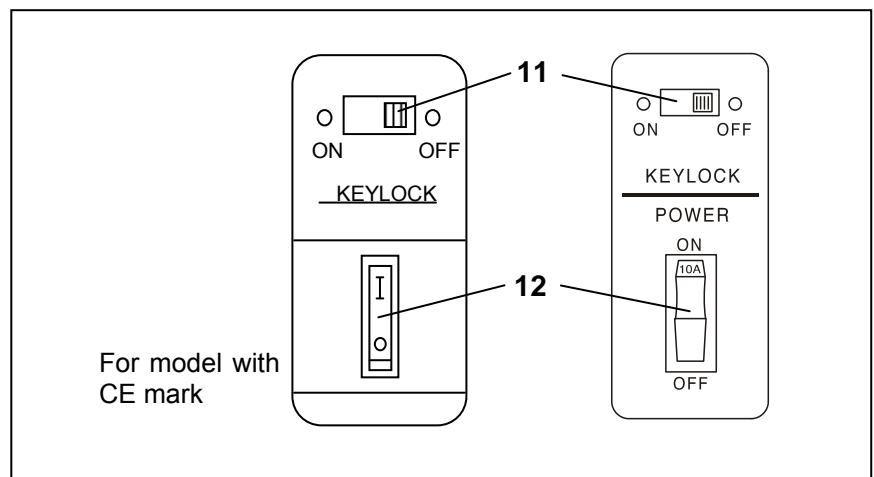
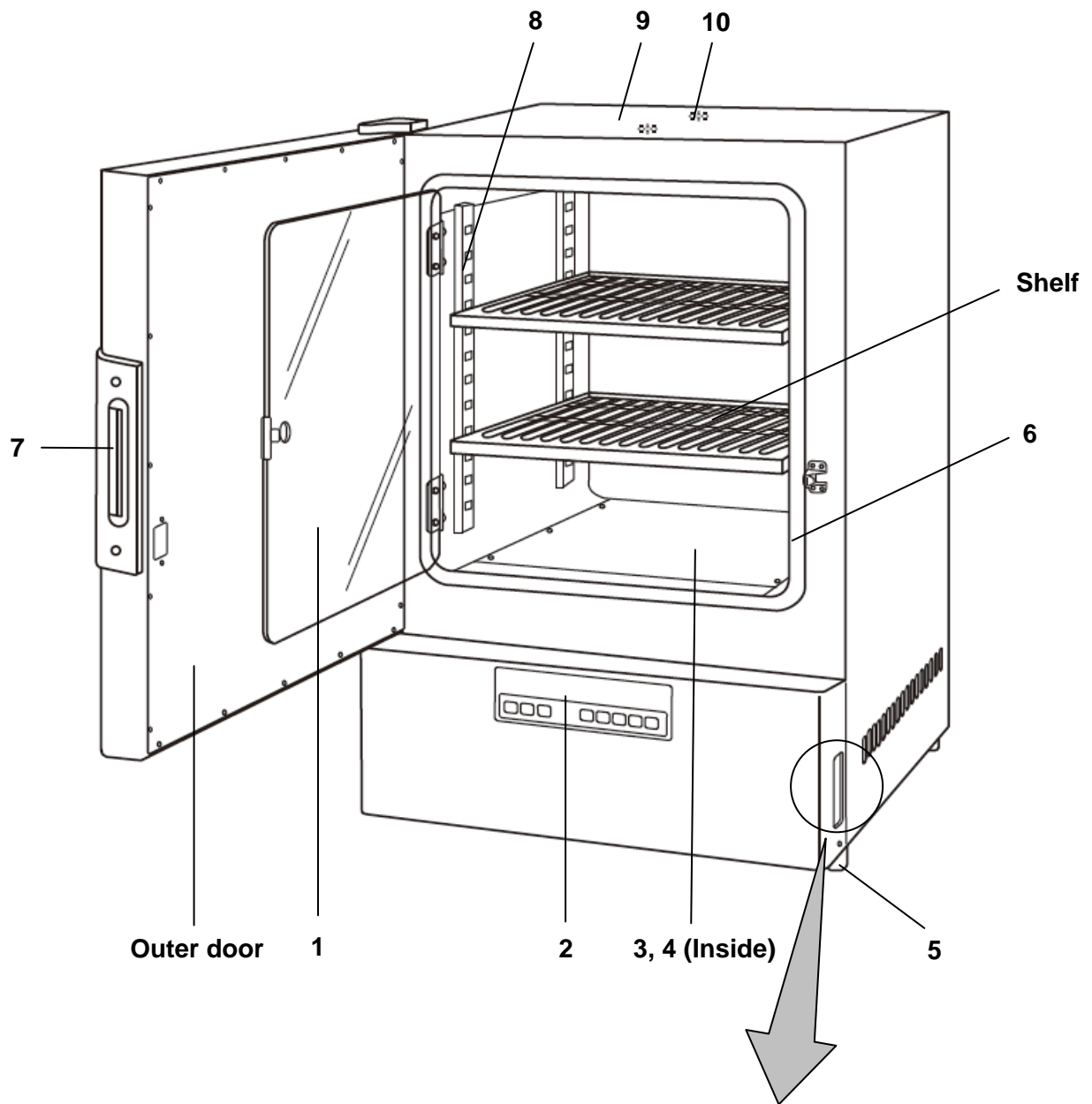

INCUBATOR COMPONENTS

1. **Inner door:** It is made of tempered glass. However, do not force the door.
2. **Control panel:** Refer to page 10.
3. **Separation plate:** Do not place objects directly on the plate.
4. **Heater box (inside):** The heater is attached under separation plate.
5. **Leveling foot:** Can be adjusted by screws. Turn the screw counterclockwise to shorten the length of the leveling foot.
6. **Gasket:** Be careful not to scratch the gasket.
7. **Handle:** Pull the knob of inside of the handle to open the door.
8. **Shelf support:** This can be adjusted to change the height.
9. **Temperature sensor (installation position):** Be careful not to allow objects to touch or scratch the sensor.
10. **Exhaust air vent:** Do not put anything on this unit as an exhaust air vent may become hot during operation. Make sure that the exhaust air vent is not blocked so that a temperature is controlled correctly.
11. **Key lock switch:** This switch is to prevent a set value from being changed by accidentally pressing a key on the control panel. Turn on this switch to set the key-lock so that the set value can not be changed.
Note: Turn off this switch when inputting the set value.
12. **Main power switch with circuit breaker:** Main switch for all power. When the operation of the unit is stopped by this circuit breaker, contact our sales representative or agent after disconnected the power supply plug.

CAUTION

Do not touch an air vent during operation, as this may cause burn injury.

INCUBATOR COMPONENTS

Control panel and keypad

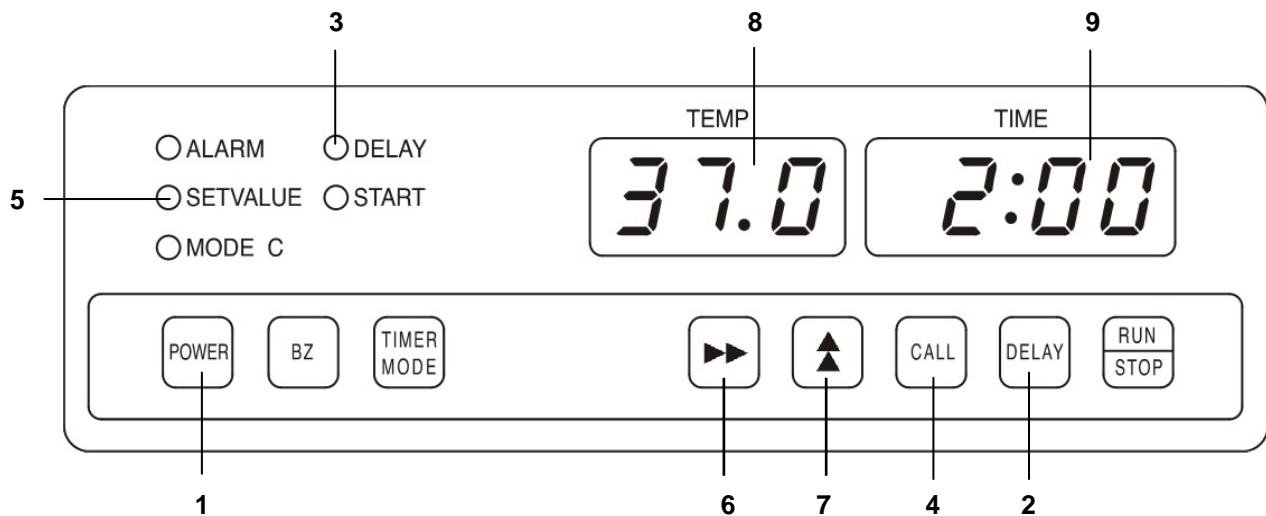

1. Power switch (POWER): Power switch of the control panel.

2. Delay timer key (DELAY): This key is to set a delay timer which controls the time from when the run/stop key (RUN/STOP) is pressed till when the unit starts an operation. Refer to page 14~17.

3. Delay timer lamp (DELAY): This lamp lights while a delay timer is being set.

4. Call key (CALL):

(During stop operation) A set value lamp (SETVALUE) lights and a setting mode is entered by pressing this key. A temperature and an operation timer can be set (Refer to page 14~17)..

(During operation) A set value lamp (SETVALUE) lights and a set value display mode is entered by pressing this key. A setting temperature and a setting time of operation timer are displayed (Table 1 on next page). By re-pressing this key, the set value lamp goes out and the mode returns to normal. In a set value display mode, a set value cannot be changed.

5. Set value lamp (SETVALUE): In a setting mode or when a set value display mode is entered by pressing a call key during operation, this lamp lights.

6. Digit shift key (▶▶): In setting mode, press this key to shift a digit to be set. Also, press this key to shift a digit to be set from the digital temperature indicator (TEMP) to the digital timer indicator (TIME).

7. Numerical value shift key (▲): Press this key to shift a numerical value in setting mode.

8. Digital temperature indicator (TEMP): Refer to Table 1 on next page.

9. Digital timer indicator (TIME): Refer to Table 1 on next page.

INCUBATOR COMPONENTS

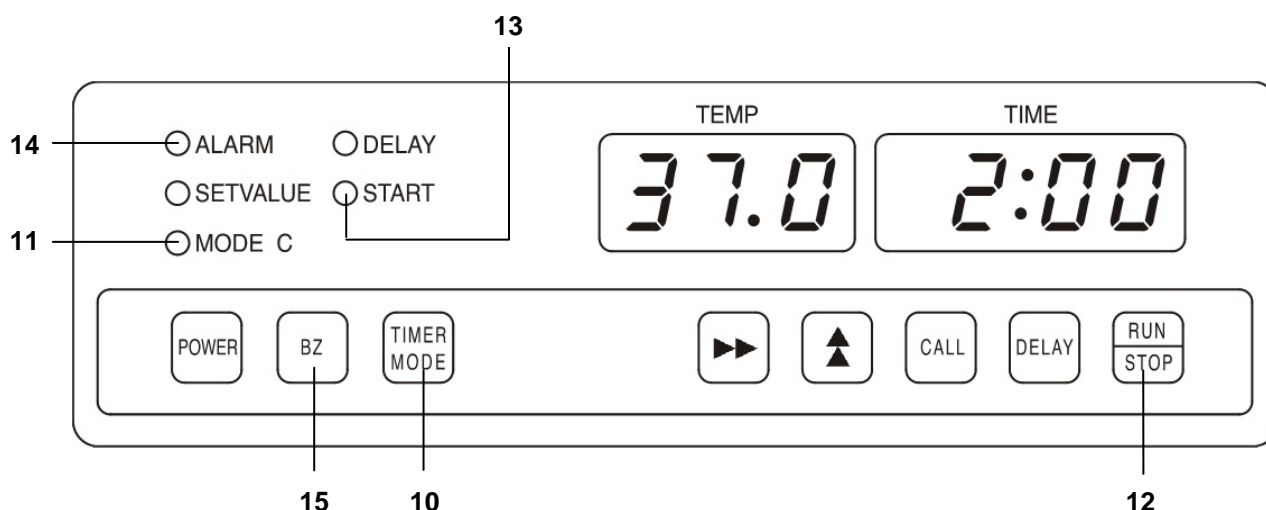

10. Timer mode select key (TIMER MODE): This key is to switch a normal mode and a timer mode C. Normal mode: The operation is finished when a set time of operation timer is expired. Timer mode C: The operation continues with a set temperature even when a set time of operation timer is expired. Refer to page 15.

11. Timer mode C lamp (MODE C): This lamp lights when a timer mode C is active.

12. Run/Stop key (RUN/STOP): In a setting mode, press this key to start operation after setting. During operation, press this key to finish operation (Refer to page 14~17).

Note: Except for a setting mode, an operation cannot be started by pressing this key.

13. Start lamp (START): This lamp lights when the unit is operating.

Note: This lamp lights when a delay timer is being set or when a continuous operation is being set after an operation timer is finished.

14. Alarm lamp (ALARM): This lamp lights when the unit is in warning condition.

15. Alarm buzzer stop key (BZ): Press this key to silence the buzzer in the event that the alarm operates and the buzzer sounds. Press it once again to reactive the buzzer.

Table 1: Display in the digital temperature indicator and digital timer indicator.

		Set value lamp	Digital temperature Indicator (TEMP)	Digital timer indicator (TIME)
During stop operation		OFF	Present temperature	—
During operation	When a delay timer is being set.	OFF	Present temperature	Remaining time of delay timer
		ON	Set temperature	Set time of operation timer*
	When an operation time is being set.	OFF	Present temperature	Remaining time of operation timer*
		ON	Set temperature	Set time of operation timer*
	(In case of Timer mode C) When a continuous operation is being set after a operation timer is finished.	OFF	Present temperature	“--:--“
		ON	Set temperature	Set time of operation timer*

*: When a continuous operation is being set in a operation timer, “--:--“ is displayed.

INSTALLATION SITE

To operate this unit properly and to obtain maximum performance, install the unit in a location with the following conditions:

■ **A location not subjected to direct sunlight**

Do not install the unit under direct sunlight. Installation in a place with direct sunlight cannot obtain the intended performance.

■ **A location with adequate ventilation**

Leave at least 30 cm around the unit for ventilation. Poor ventilation will result in a reduction of the performance.

■ **A location away from heat generating sources**

Avoid installing the unit near heat-emitting appliances such as a heater or a boiler, etc. Heat can decrease the intended performance of the unit.

■ **A location with a sturdy and level floor**

Always install the unit on a sturdy and level floor. The uneven floor or tilted installation may cause failure or injury. Install the unit in stable condition to avoid the vibration or noise. Unstable condition may cause vibration or noise.

 **WARNING**

Install the unit on a sturdy floor. If the floor is not strong enough or the installation site is not adequate, this may result in injury from the unit falling or tipping over.

Select a level and sturdy floor for installation. This precaution will prevent the unit from tipping. Improper installation may result in water spillage or injury from the unit tipping over.

■ **A location not prone to high humidity**

Install the unit in the ambient of 80% R.H. or less humidity. Installation under high humidity may cause current leakage or electric shock.

 **WARNING**

Do not use the unit outdoors. Current leakage or electric shock may result if the unit is exposed to rain water.

Never install the unit in a humid place or a place where it is likely to be splashed by water. Deterioration of the insulation may result which could cause current leakage or electric shock.

■ **A location without flammable or corrosive gas**

Never install the unit in a flammable or volatile location. This may cause explosion or fire or may result in the current leakage or electric shock by the corrosion of the electrical components.

INSTALLATION

1. Remove the packaging materials and tapes

Remove all transportation packaging materials and tapes. Open the doors and ventilate the unit. If the outside panels are dirty, clean them with a neutral detergent and wipe it up with a wet cloth.

Note:

Remove the cable tie banding the power supply cord. Prolonged banding may cause the corrosion of the cord coating.

2. Adjust the leveling feet

Extend the leveling feet by rotating them counterclockwise so that they contact with a floor or a bench. Ensure the unit is level.

3. Ground (earth)

WARNING

Use a power supply outlet with ground (earth) to prevent electric shock. If the power supply outlet is not grounded, it is necessary to install a ground by qualified engineers.

Never ground the unit through a gas pipe, water main, telephone line or lightning rod. Such grounding may cause electric shock in the case of an incomplete circuit.

PRELIMINARY RUN

When using the unit for the first time after purchasing, operate the unit without any object inside it.

1. Install the racks in the chamber.
2. Set the temperature at 60 °C and operate the unit for 20 minutes.
3. Leave the unit until the chamber temperature is cool enough.
4. Ventilate the room when opening the chamber door as the smoke with a strong odor is exhausted.
5. Keep the chamber door open for a while until the odor is eliminated.

Note:

Some odors may be remained after the preliminary run. Such residue is eliminated gradually during usage.

- With the use of a unit, the inner surfaces, shelves and the separation plate may be discolored by smoke generated inside a unit. This is a natural discoloration.
- This unit has been tested at the factory before shipping. Therefore, light lines and/or discoloration may be detected even though the unit is a new one.

KEY OPERATION FLOW

This flow chart shows the key operation from control panel.

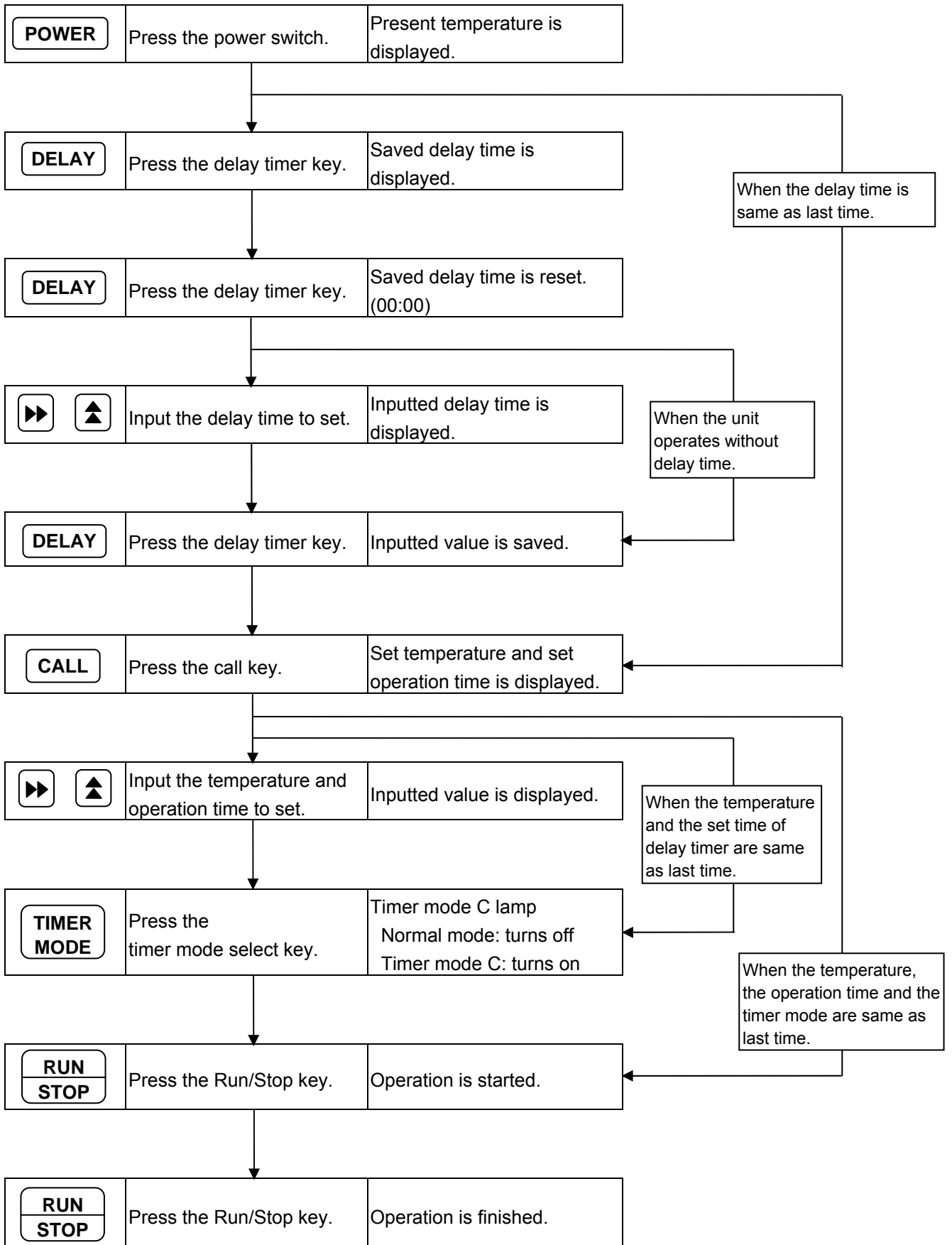

NORMAL MODE AND TIMER MODE C

The operation flow of this unit in the normal mode and the timer mode C is shown in Table 2 and Table 3.

Table 2 Operation flow in normal mode (Timer mode C lamp: OFF)

●: Lamp ON ○: Lamp OFF

Key operation Behavior of unit		Automatic termination* ¹ Buzzer		
		When a delay timer being set	When an operation timer being set.	During stop operation
Chamber temperature graph (Image)				
Start lamp		●	●	○
Delay timer lamp		●	○	○
Digital temperature indicator	○SETVALUE	Present temperature	Present temperature	Present temperature
	●SETVALUE	Set temperature	Set temperature	—
Digital timer indicator	○SETVALUE	Remaining time of delay time	Remaining time of operation timer* ²	—
	●SETVALUE	Set time of operation time* ²	Set time of operation timer* ²	—

Table 3 Operation flow in timer mode C (Timer mode C lamp: ON)

●: Lamp ON ○: Lamp OFF

Key operation Behavior of unit		Buzzer* ³			
		When a delay timer being set	When an operation timer being set.	During continuous operation	During stop operation
Chamber temperature graph (Image)					
Start lamp		●	●	●	○
Delay timer lamp		●	○	○	○
Digital temperature indicator	○SETVALUE	Present temperature	Present temperature	Present temperature	Present temperature
	●SETVALUE	Set temperature	Set temperature	Set temperature	—
Digital timer indicator	○SETVALUE	Remaining time of delay time	Remaining time of operation timer* ²	“--:--“	—
	●SETVALUE	Set time of operation time* ²	Set time of operation timer* ²	Set time of operation timer* ²	—

*1: Since an operation timer is not be finished when a continuous operation (--:--) is being set in the operation timer, press the run/stop key (RUN/STOP) to stop operation.

*2: When a continuous operation (--:--) is being set in an operation timer, “--:--“ is displayed.

*3: Since an operation timer is not finished when a continuous operation (--:--) is being set in the operation timer, the buzzer will not be sounded.

STABLE RUNNING

Table 4 shows the basic procedure for setting the chamber temperature. Perform key operations in the sequence indicated in the table. The example in the table is based on the assumption that the desired temperature is 37 °C and the operation status is a continuous running.

Note: The initial setting, which are set at factory, are that the delay timer is OFF, the chamber temperature is 0 °C, the running time is ever ON, the timer mode is the normal mode.

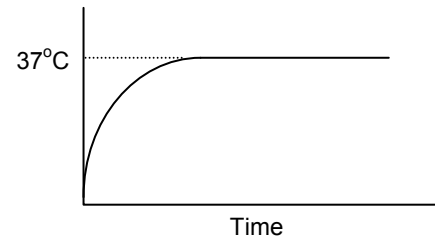

Table 4: Basic operation sequence (Example: Chamber temperature; 37 °C, Continuous running)

	Description of operation	Key operated	Indication after operation
1	Press the power key.		The current chamber temperature is displayed. 20.0 :
2	Press the delay timer key.		The current delay time is displayed. : :
3	Press the delay timer key to reset the delay time.		Reset the delay time. : :
4	Press the delay timer key		The current chamber temperature is displayed. 20.0 :
5	Press the call key.		The left digit of the temperature indicator flashes. 00.0 - - : - -
6	Set the temp. to 37.0 with the digit shift key and the numeric value shift key.		37.0 - - : - -
9	Press the run/stop key.		The setting mode is completed and the unit runs.

STABLE RUNNING WITH DELAY TIME

Table 5 shows one of applications. Perform key operations in the sequence indicated in the table. The example in the table is the delay time that is 30 minutes, the chamber temperature is 50 °C, the running time is 1 hour and the timer mode is Timer Mode C.

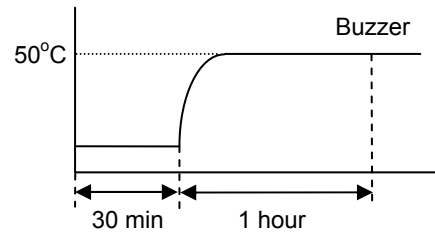

Table 5: Basic operation sequence (Example: Chamber temperature; 50 °C, Delay time; 30 minutes, Running time; 1 hour, Timer mode; C)

	Description of operation	Key operated	Indication after operation
1	Press the power key.	POWER	The current chamber temperature is displayed. 20.0 :
2	Press the delay timer key.	DELAY	The current delay time is displayed. : :
3	Press the delay timer key to reset the delay time.	DELAY	Reset the delay time. : :
4	Set the delay time to 00:30 with the digit shift key and the numeric value shift key.	▶▶ ▲	: : 30
5	Press the delay timer key.	DELAY	The current chamber temperature is displayed. 20.0 - - : - -
6	Press the call key.	CALL	The left digit of the temperature indicator flashes. 00.0 - - : - -
7	Set the temp. to 50.0 and the running time to 01:00 with the digit shift key and numeric value shift key.	▶▶ ▲	50.0 01:00
8	Press the timer mode key to select the time mode C.	TIMER MODE	By pressing the key, the timer mode C lamp lights.
9	Press the run/stop key.	RUN STOP	The setting mode is completed and the unit runs. : : 30

Note:

If there is no need to change the set value in each setting mode, press the call key (CALL) to activate the next mode.

When setting a continues operation, set "--:--" in the leftmost digit of distal timer indicator (TIME) with numerical value shift key on the procedure 7 in Table 5.

Press the Run/Stop key (RUN/STOP) when the setting mode needs to be canceled while running of the unit.

When the delay timer doesn't need to be activated, set the delay time to 00:00.

When the set value needs to be changed, operate a key after the unit stops.

When no key is pressed for 45 seconds, displayed number is memorized, setting is over and indicator displays the current value.

ALARMS AND SAFETY FUNCTIONS

The incubator supports the following alarms, safety functions, and self-diagnostic functions.

Alarms and safety functions

Alarm & Safety	Situation	Indication	Buzzer	Safety operation
Automatic set temperature alarm	The internal temperature is over ± 2.5 °C from the set temp..	Alarm lamp lights. All digits on the temp. indicator flash.	Intermittent tone	----
Key lock switch	When the key lock switch is turned ON.	----	----	Key input is disabled.
Temperature sensor abnormality	The temperature sensor is disconnected.	Alarm lamp lights. E01 is displayed on the temp. indicator.	Intermittent tone	Heater OFF
Triac abnormality	The triac is disconnected.	Alarm lamp lights. E02 is displayed on the temp. indicator.	Intermittent tone	Heater OFF
	The triac is short-circuited.	Alarm lamp lights. E03 is displayed on the temp. indicator.	Intermittent tone	Heater OFF
Relay abnormality	The relay is short-circuited.	Alarm lamp lights. E04 is displayed on the temp. indicator.	Intermittent tone	Heater OFF
	The relay is disconnected or the heater is short-circuited.	Alarm lamp lights. E05 is displayed on the temp. indicator.	Intermittent tone	Heater OFF
Independent over-heat protection	(When the unit is not running) The safety circuit is activated by independent temp. sensor if the chamber is being overheated abnormally.	Without display change.	Continuous tone	Heater OFF forcedly by external circuit.
	(When the unit is running) The safety circuit is activated by independent temp. sensor if the chamber is being overheated abnormally.	Alarm lamp lights. E05 is displayed on the temp. indicator.	Continuous tone (When the temp. is decreased, intermittent tone)	Heater OFF forcedly by external circuit.

* The buzzer tone resulting from the independent over-heat protection cannot be stopped with the alarm buzzer stop key (BZ). Turn off the main switch.

Operation after power failure

The set value is memorized by nonvolatile memory. Accordingly, the heated incubator resumes the operation with setting before power failure.

ROUTINE MAINTENANCE

WARNING

Always disconnect the power supply to the unit prior to any repair or maintenance of the unit in order to prevent electric shock or injury.

Ensure you do not inhale or consume medication or aerosols from around the unit at the time of maintenance. These may be harmful to your health.

CAUTION

Always put on dry gloves to protect hands at the time of maintenance. Failure to use gloves may result in cuts or abrasions from any sharp edges or corners.

Note:

Never attempt to directly spray water on the heater box or the inside of the oven as it is very dangerous. In addition, never use volatile or combustible chemicals to clean the inside.

Cleaning of unit

Cleaning the inside

- Remove all shelves from the inside.
- Clean the inside using a soft cloth damped with neutral detergent. Afterwards, wipe off with a cloth washed in clean water.
- Remove the separation plate at the bottom of the oven and wipe off any particles in the heater box, using a soft cloth damped with water.

Cleaning the frame

- Clean the frame using a soft cloth damped with neutral detergent. Afterwards, wipe it up the detergent with a wet cloth.

Cleaning the shelf

- To clean the shelf, place it in a tub of warm water mixed with neutral detergent and wipe with a sponge or a soft cloth. Shelves used at high temperature may be discolored naturally.

CAUTION

When cleaning, do not use brushes, acids, benzine, thinner, soap, cleaner or hot water. These will cause discoloring or damage to coated surfaces. On plastic or rubber parts, they will cause transformation, discoloration or degeneration. Never apply volatile chemicals (like benzine etc.) on plastic or rubber parts. When neutral detergent is used, be sure to wipe it up thoroughly with a wet cloth afterwards.

TROUBLE SHOOTING

If the unit malfunctions, check out the following before calling for service.

Malfunction	Check/Remedy
The unit does not operate at all.	<ul style="list-style-type: none"> • The unit is not plugged correctly into a power outlet. • The circuit breaker at the power source is active. • A power failure has occurred. • A fuse has blown.
The key operation is disable	<ul style="list-style-type: none"> • The key lock function is set in ON mode.
If the alarm function and the buzzer operate	<p>[At the beginning of operation]</p> <ul style="list-style-type: none"> • The chamber temperature does not match the set value. <p>[During operation]</p> <ul style="list-style-type: none"> • Has the set temperature value been changed? Has the door been left open for a long time? • Has a low-temperature object been placed in the unit? In this case, the alarm will be automatically cleared in a while.
If the chamber temperature does not match the set value.	<ul style="list-style-type: none"> • Is the temperature in the vicinity too high? The ambient temperature must always be at least 5 °C less than the set temperature. If the ambient temperature rises by the value above, consider the air conditioning in the room. • Is the unit installed tilted? Install the unit horizontally.

Note:

If the malfunction is not eliminated after checking the above items, or the malfunction is not shown in the above table, contact our sales representative or agent.

DISPOSAL OF UNIT

WARNING

If the unit is to be stored unused in an unsupervised area for an extended period **ensure that children do not have access and doors cannot be closed completely.**

The disposal of the unit should be undertaken by appropriate personnel. Always remove doors to prevent accidents such as suffocation.

DISPOSAL OF UNIT

Note:

This symbol mark and recycle system are applied only to EU countries and not applied to the countries in the other area of the world.

Waste Electrical and Electronic Equipment (WEEE) Directive



(English)

Your Panasonic product is designed and manufactured with high quality materials and components which can be recycled and reused.

This symbol means that electrical and electronic equipment, at their end-of-life, should be disposed of separately from your household waste.

Please dispose of this equipment at your local community waste collection/recycling centre.

In the European Union there are separate collection systems for used electrical and electronic products.

Please help us to conserve the environment we live in!

(German)

Ihr Panasonic Produkt wurde entworfen und hergestellt mit qualitativ hochwertigen Materialien und Komponenten, die recycelt und wiederverwendet werden können.

Dieses Symbol bedeutet, daß elektrische und elektronische Geräte am Ende ihrer Nutzungsdauer von Hausmüll getrennt entsorgt werden sollen.

Bitte entsorgen Sie dieses Gerät bei Ihrer örtlichen kommunalen Sammelstelle oder im Recycling Centre.

In der Europäischen Union gibt es unterschiedliche Sammelsysteme für Elektrik- und Elektronikgeräte.

Helfen Sie uns bitte, die Umwelt zu erhalten, in der wir leben!

DISPOSAL OF UNIT



(French)

Votre produit Panasonic est conçu et fabriqué avec des matériaux et des composants de qualité supérieure qui peuvent être recyclés et réutilisés.

Ce symbole signifie que les équipements électriques et électroniques en fin de vie doivent être éliminés séparément des ordures ménagères.

Nous vous prions donc de confier cet équipement à votre centre local de collecte/recyclage.

Dans l'Union Européenne, il existe des systèmes sélectifs de collecte pour les produits électriques et électroniques usagés.

Aidez-nous à conserver l'environnement dans lequel nous vivons !

Les machines ou appareils électriques et électroniques contiennent fréquemment des matières qui, si elles sont traitées ou éliminées de manière inappropriée, peuvent s'avérer potentiellement dangereuses pour la santé humaine et pour l'environnement.

Cependant, ces matières sont nécessaires au bon fonctionnement de votre appareil ou de votre machine. Pour cette raison, il vous est demandé de ne pas vous débarrasser de votre appareil ou machine usagé avec vos ordures ménagères.

(Spanish)

Los productos Panasonic están diseñados y fabricados con materiales y componentes de alta calidad, que pueden ser reciclados y reutilizados.

Este símbolo significa que el equipo eléctrico y electrónico, al final de su ciclo de vida, no se debe desechar con el resto de residuos domésticos.

Por favor, deposite su viejo equipo en el punto de recogida de residuos o contacte con su administración local.

En la Unión Europea existen sistemas de recogida específicos para residuos de aparatos eléctricos y electrónicos.

Por favor, ayúdenos a conservar el medio ambiente!

DISPOSAL OF UNIT



(Portuguese)

O seu produto Panasonic foi concebido e produzido com materiais e componentes de alta qualidade que podem ser reciclados e reutilizados.

Este símbolo significa que o equipamento eléctrico e electrónico no final da sua vida útil deverá ser descartado separadamente do seu lixo doméstico.

Por favor, entregue este equipamento no seu ponto local de recolha/reciclagem.

Na União Europeia existem sistemas de recolha separados para produtos eléctricos e electrónicos usados.

Por favor, ajude-nos a conservar o ambiente em que vivemos!

(Italian)

Il vostro prodotto Panasonic è stato costruito da materiali e componenti di alta qualità, che sono riutilizzabili o riciclabili.

Prodotti elettrici ed elettronici portando questo simbolo alla fine dell'uso devono essere smaltiti separatamente dai rifiuti casalinghi.

Vi preghiamo di smaltire questo apparecchio al deposito comunale.

Nell'Unione Europea esistono sistemi di raccolta differenziata per prodotti elettrici ed elettronici.

Aiutateci a conservare l'ambiente in cui viviamo!

DISPOSAL OF UNIT



(Dutch)

Panasonic producten zijn ontwikkeld en gefabriceerd uit eerste kwaliteit materialen, de onderdelen kunnen worden gerecycled en weer worden gebruikt.

Het symbool betekent dat de elektrische en elektronische onderdelen wanneer deze vernietigd gaan worden, dit separaat gebeurt van het normale huisafval.

Zorg ervoor dat het verwijderen van de apparatuur bij de lokaal erkende instanties gaat gebeuren. In de Europese Unie wordt de gebruikte elektrische en elektronische apparatuur bij de daarvoor wettelijke instanties aangeboden.

Alstublieft help allen mee om het milieu te beschermen.

(Swedish)

Din Panasonic produkt är designad och tillverkad av material och komponenter med hög kvalitet som kan återvinnas och återanvändas.

Denna symbol betyder att elektriska och elektroniska produkter, efter slutanvändande, skall sorteras och lämnas separat från Ditt hushållsavfall.

Vänligen, lämna denna produkt hos Din lokala mottagningstation för avfall/återvinningsstation.

Inom den Europeiska Unionen finns det separata återvinningssystem för begagnade elektriska och elektroniska produkter.

Vänligen, hjälp oss att bevara miljön vi lever i!

SPECIFICATIONS

Product name	Heated Incubator MIR-H163	Heated Incubator MIR-H263
External dimensions	W580 mm x D595 mm x H820 mm	W730 mm x D645 mm x H870 mm
Internal dimensions	W450 mm x D460 mm x H450 mm	W600 mm x D510 mm x H500 mm
Effective capacity	93 L	153 L
Exterior	Painted steel	
Interior	Stainless steel plate (SUS 304)	
Outer door	Painted steel	
Inner door	Tempered glass	
Insulation	Glass wool	
Shelf	Stainless steel plate (SUS 304), 2 pcs.	Stainless steel plate (SUS 304), 3 pcs.
Shelf support	4	6
Temperature controller	Sensor K, PID control	
Temperature display	Digital display	
Timer	Electronic timer with delay timer	
Circuit breaker	10 A	
Overheat prevention mechanism	Built-in thermister (electric circuit), Thermal guard	
Heater	200 W	300 W
Weight	44 kg	61 kg

Note: Design or specifications will be subject to change without notice.

PERFORMANCE

Product name	Heated Incubator MIR-H163			
Model No.	MIR-H163-PA	MIR-H163-PK	MIR-H163-PE	MIR-H163-PU
Temperature control range	Ambient temperature+5 °C to 60 °C (setting available to 80 °C)			
Temperature fluctuation	±0.5 °C			
Temperature variation	±1 °C (at 37 °C)			
Rated voltage	AC 115 V	AC 220 V	AC 230 V	AC 240 V
Rated frequency	60 Hz	60 Hz	50 Hz	50 Hz
Rated power consumption	200 W	200 W	200 W	200 W

Product name	Heated Incubator MIR-H263				
Model No.	MIR-H263-PA	MIR-H263-PK	MIR-H263-PR	MIR-H263-PE	MIR-H263-PU
Temperature control range	Ambient temperature+5 °C to 60 °C (setting available to 80 °C)				
Temperature fluctuation	±0.5 °C				
Temperature variation	±1 °C (at 37 °C)				
Rated voltage	AC 115 V	AC 220 V		AC 230 V	AC 240 V
Rated frequency	60 Hz	60 Hz	50 Hz	50 Hz	
Rated power consumption	300 W	300 W		300 W	300 W

Note: The unit with CE mark complies with EC directives.

CAUTION

**Please fill in this form before servicing.
Hand over this form to the service engineer to keep for his and your safety.**

Safety check sheet

1. Incubator contents :

- Risk of infection: Yes No
Risk of toxicity: Yes No
Risk from radioactive sources: Yes No

(List all potentially hazardous materials that have been stored in this unit.)

Notes :

2. Contamination of the unit

Unit interior

- No contamination Yes No
Decontaminated Yes No
Contaminated Yes No

Others:

3. Instructions for safe repair/maintenance of the unit

- a) The unit is safe to work on Yes No
b) There is some danger (see below) Yes No

Procedure to be adhered to in order to reduce safety risk indicated in b) below.

Date :

Signature :

Address, Division :

Telephone :

Product name : Heated Incubator	Model No. MIR-	Serial number :	Date of Installation :
------------------------------------	-------------------	-----------------	------------------------

Please decontaminate the unit yourself before calling the service engineer.

Panasonic Healthcare Co., Ltd.

1-1-1, Sakata Oizumi-Machi Ora-Gun, Gunma 370-0596, Japan

© Panasonic Healthcare Co., Ltd. 2014

Printed in Indonesia
7FB6P15175600
S1014-0